

# CONEXÕES NAKRAM

## EM ALUMÍNIO EXTRUDADO

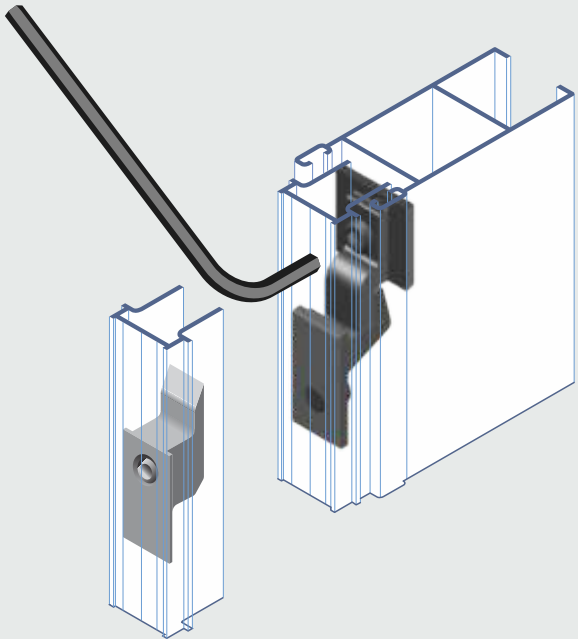

Linha de  
contra-fechos  
em alumínio  
extrudado  
Nakram:

**CON-370**

**CON-409**

**CON-452**

**CON-382/383**

**SUP-622**

Os melhores componentes  
para portas e janelas de  
correr. Suas principais  
características:

- NÃO QUEBRA
- NÃO DEFORMA
- NÃO OXIDA
- LIVRE DE MANUTENÇÃO
- O MELHOR CUSTO/BENEFÍCIO
- PARAFUSO DE INOX
- SIMPLEMENTE O MELHOR!

**CON-370**



CONTRA FECHO PARA PORTAS E JANELAS DE CORRER  
ACABAMENTO PRETO E BRANCO

**CON-409**

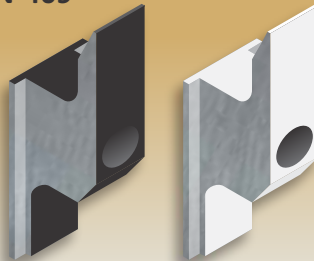

**CON-452**



TRAVA FOLHA FIXA  
LINHA MASTER

**CON-382/383**

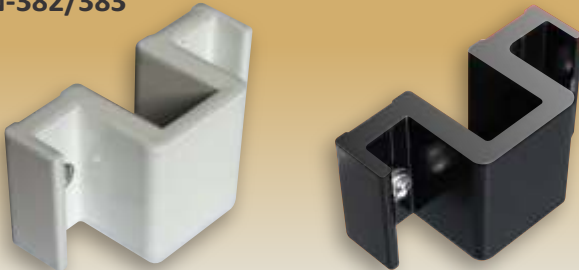

CONTRA-FECHO CONCHA/FECHADURA LATERAL GDL BP3 (CON382/383)  
ACABAMENTO PRETO / BRANCO

**SUP-622**

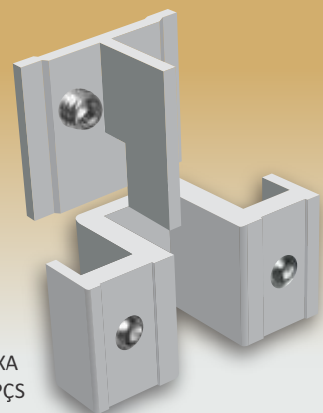

TRAVA FOLHA FIXA  
SP803\* S/A C/ 2 PÇS



**NAKRAM Ind. e Com. Ltda.**  
Av. Engº Alberto de Zagottis 1.099  
04675-085 • Jurubatuba  
São Paulo • SP

☎ 55 (11) 5686 7587 / 5681 8912  
📞 (11) 91099 3253  
✉ [nakram@nakram.com.br](mailto:nakram@nakram.com.br)  
🌐 [www.nakram.com.br](http://www.nakram.com.br)